

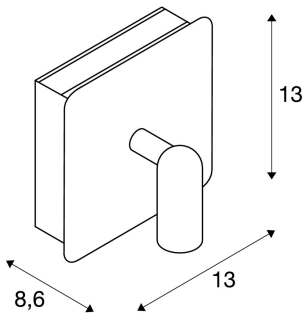

## NAPIA

wall light, LED, 3000K, round, green, incl. LED driver and switch

The NAPIA reading Luminaire is available in a number of trendy colours to match any interior design style. Beyond puristic and modern design, the NAPIA is equipped with two Premium LEDs, enabling direct and indirect lighting. Thanks to integrated switches, both light apertures can be controlled separately. The installed 350mA driver allows it to be directly connected to the 230V mains supply.



## TECHNICAL DATA

Item no.:	155105
Lamps included	0
Number of different light outlets	2
Primary nominal voltage	220-240V ~50/60Hz mA/V
Secondary power / secondary voltage	350 mA/V
Vertical tilting range	90 °
Horizontal rotation range	350 °
Width	13.0 cm
Height	13.0 cm
Depth	8.6 cm
Net weight	0.537 kg
Gross weight	0.624 kg
IP Code	IP 20
Safety class	I
Assembly	Surface
Assembly details	Wall
Wattage	3.8 W
Lumen	157 lm
Colour temperature	3000 Kelvin
Beam angle	32 °
Color	green
CRI	>80



Binning	6
Binning 2	6
LXXBXX data	70/50
Service life	35000 h
Service life 2	35000 h

**Notes**

---

---

---

---

---